

## **5-wire Resistive Touchscreen Specifications**

- 1. Mechanical**
- 2. Optical**
- 3. Reliability**
- 4. Environmental**
- 5. Electrical**
- 6. Cosmetic Quality**
- 7. Cautions**
- 8. Warranty**



## 1. Mechanical

### 1.1 Construction

5-wire resistive touchscreen is composed of glass (bottom layer) coated with transparent conductive material (ITO) film (top layer) and top and bottom layers touch screen each other, and electric analog X, Y signals are transmitted to the touch controller. The analog signals transmitted from the panel are converted to digital signals by the A/D converter of the controller and then transmitted to the control driver of each operating system. The software of driver is optimized to operate the touch panel for each operating system by receiving digital signals converted from the controller.

The connector shall be capable of at least 100 insertions and withdrawals of a compatible male contact without affecting the electrical performance of the touchscreen. The cable to touchscreen interface shall be capable of withstanding a straight-line pull of 10 pounds, maintained for a period of five minutes. The cable to connector housing interface shall be capable of withstanding a straight-line pull of eight pounds, maintained for a period of five minutes.

### 1-2 Features

- Analog Resistive Type Touchscreen with 5-wire technology.
- Input Mode: Finger, Gloved finger or Stylus pen
- Input Method

Pen : 110 g © (Polyacetal)  
Finger: 110 g © (Silicon rubber)

- Structure

PET(ITO Film) ----- Anti-Glare Film , 188 ± 15%(T), 3H  
Clear Film , 188 ± 15%(T), 3H

Glass ----- ITO Glass 1.8, 2.9 mm ± 10%(T)

- Connector: FFC tail, 5-pin, Pitch=2.54 (mm)
- Tape: Gasket -- 80
- Controller: Serial, USB

### 1-3 Linearity Accuracy

Standard deviation of error is less than 2% error on most displays. Detected touch coordinates, after being mathematically fitted to actual touch coordinate patterns, shall not have a standard deviation of error in excess of 1.5% in either axis using Test software as the data collection and calculation tool

- Criterion Direction 「X」 : 1.5 % or less  
Direction 「Y」 : 1.5 % or less

### 1-4 Touch Activation Force

When activated by a “Standard Finger” , the activating force is typically less than 110 grams.

### 1-5 Hard coat Pencil Hardness

Meets pencil hardness 3H.

### 1-6 Surface Durability

Surface durability is tested as follows:

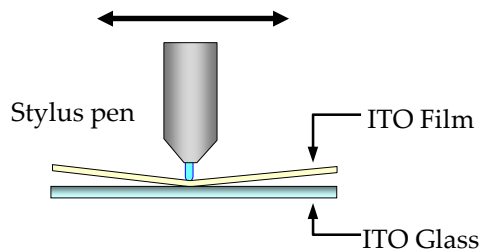

As shown above the touchscreen is mounted on measuring equipment and then stroked 10,000 times straight line in one location of the ITO film hard coated on panel by stylus pen with pressure. The pen speed is  $100 \pm 15$  mm per second with 250gf of force of pressure. Abrasion test will be reported well if there is no abrasion shown up with the above procedure without failure.

## 2. Optical

- Light Transmittance (Total Transmittance)

81% @ (550 wavelength, According to JIS-K7105)

### 3. Reliability

#### 3-1 Charter writing operation (Iterated drawing in 20mm x 20mm squares)

Writing 10,000,000 characters must satisfy requirements in paragraphs 1-3 and 5-1.

Writing of alphanumerical characters must be done in the following manner at any point within an effective area.

- 1) Testing equipment : Pen plotter
- 2) Testing load / force : 250gf
- 3) Sliding speed : 100mm/second
- 4) Tip probe : R0.8 polyacetal stylus

#### 3-2 Rubber stroke operation

30,000,000 strokes with a piece of rubber must satisfy requirements in paragraphs 1-3 and 5-1.

Hits must be made in the following manner at any point within at effective area.

- 1) Testing equipment : Pen plotter
- 2) Testing load : 250gf
- 3) Press speed : 2 hits/second
- 4) Tip probe : silicon rubber R8.0, hardness shore 12

#### 3-3 Shock resistance

Requirement in paragraphs 1-3 and 5-1 must be satisfied.

No breakage when R10mm steel ball is dropped on the touch panel supported with the display module from 15cm height at 1 time.

### 4. Environment Durability Performance

#### 4-1 Usable Temperature Range

- Operating: -20<sup>∘</sup> ~ 70<sup>∘</sup> Humidity 90% RH at max 35<sup>∘</sup>

#### 4-2 Storage Temperature Range

- Storage: -40<sup>∘</sup> ~ 80<sup>∘</sup> Humidity 90% RH at max 35<sup>∘</sup>

#### **4-3 Relative humidity: 25 - 90%**

- Temperature:  $20 \pm 2$  °c
- Humidity :  $65 \pm 5$  % RH

#### **4-4 High Temperature Test**

Requirement in paragraphs 1-3 and 5-1 must be satisfied.

Put samples in a vessel at the condition of  $70 \pm 2$ ° and  $40 \pm 5$ % relative humidity for 120 hours. Then, leave them in a room temperature for 2 hours or more and measure it. The measurement must satisfy the items mentioned above.

#### **4-5 Low Temperature Test**

Requirement in paragraphs 1-3 and 5-1 must be satisfied.

Put samples in a vessel at the condition of  $-25 \pm 2$ ° for 120 hours. Then, leave them in a room temperature for 2 hours or more and measure it. The measurement must satisfy items mentioned above.

#### **4-6 Humidity Test**

Requirement in paragraphs 1-3 and 5-1 must be satisfied.

Leave samples in an environment of  $60 \pm 2$ ° and 90-95% relative humidity for 96 hours and then perform measurements after putting them at room temperature for 2 hours. (There must be no condensation)

#### **4-7 Thermal Shock Test**

Requirement in paragraphs 1-3 and 5-1 must be satisfied.

Put samples in a vessel at the condition of  $-40 \pm 2$ ° for 30 minutes and then the degree varies a range from  $-40 \pm 2$ ° to  $+80 \pm 2$ ° within 5 minutes, and then  $80 \pm 2$ ° for 30 minutes again as shown the figure below. This process is repeated 10 cycles and then the samples are left in a room temperature for 2 hours and measure it. The measurement must satisfy the items mentioned below.

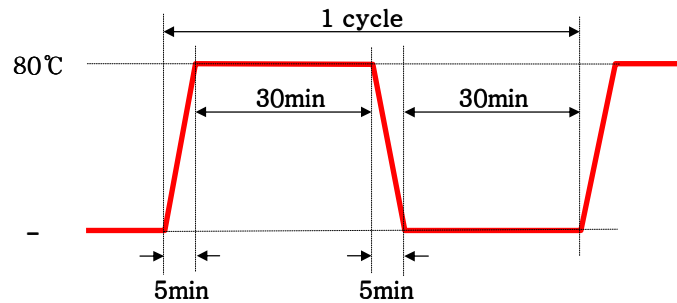

#### 4-8 Resistance to chemicals (Surface hard coating)

No abnormality in external appearance.

Lightly wipe the surface with methyl alcohol, artificial perspiration and household cleanser.

## 5. Electrical

### 5-1 Resistance between leads

- Criterion    Direction 「X」 (Glass side): 50~300Ω (Typ. 350Ω/□)  
                   Direction 「Y」 (Glass side): 50~300Ω (Typ. 350Ω/□)

### 5-2 Electrostatic Discharge Protection

Meets 24kV air/13kV contact discharges

### 5-3 Contact Bounce

Beginning of the touch pulse shall not exceed 15 milliseconds.

### 5-4 Open Circuit Resistance

The controller is designed to distinguish resistance values less than 20k ohms to filter false or near touches.

### 5-5 Closed Circuit Resistance

Shall be less than 3,000 ohms when measured between the signals contact (pin 3) to any drive contact (pin 1,2,4, or 5) on the connector when the touch screen is actuated anywhere within

the Touch Active Area with a Standard Finger exerting a force of 10 to 20 ounces.

## 5-6 Breakdown Voltage

The touch screen, with no force applied to the active surface, shall be capable of withstanding a difference of potential of 50 vdc, between the signal contact (pin 3) and any drive contact (pin 1,2,4 or 5) on the connector for a period of 5 minutes.

## 6. Cosmetic Quality

### 6-1 Inspection Condition

The inspection shall be performed by using two 14W fluorescent lamps. The panel shall be placed at 30cm away from eyes.

### 6-2 Criterion

The followings are applied to viewing area.

Any defects as below shall be ignored when invisible and unless they affect the electrical performance.

- Scratch

Width < 0.09 mm and length < 20 mm: Acceptable.

Width ≥ 0.09 mm or length ≥ 20 mm: Unacceptable.

- Film (PET) Bubbles.

Diameter ≤ 0.4 mm: Acceptable

Diameter > 0.4 mm: Unacceptable

- Blistering (Puffiness, Bagginess)

Height ≤ 0.4 mm: Acceptable

- Linear foreign object in the active area

Line Width ≤ 0.09 and X ≤ 1.5 and Y ≤ 1.5 mm under: Acceptable

Line Width > 0.09 or X > 1.5 or Y > 1.5 mm over: Unacceptable

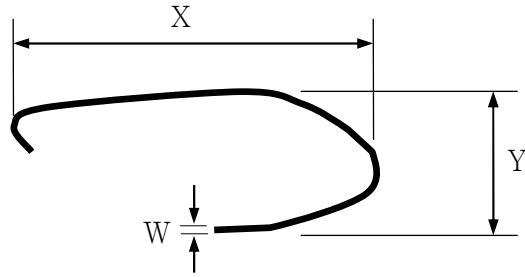

### 6-3 Glass Fragment

- Glass Crack

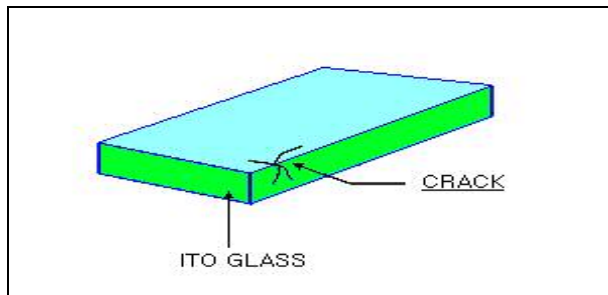

It is regarded as defective.

- Side Fragment

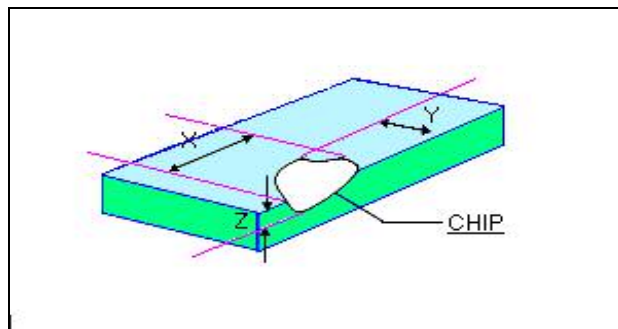

$X \leq 4\text{mm}$ ,  $Y \leq 3.0\text{mm}$  and  $Z \leq t \text{ mm}$ : It is acceptable  
(t: Glass Thickness)

- Corner Fragment

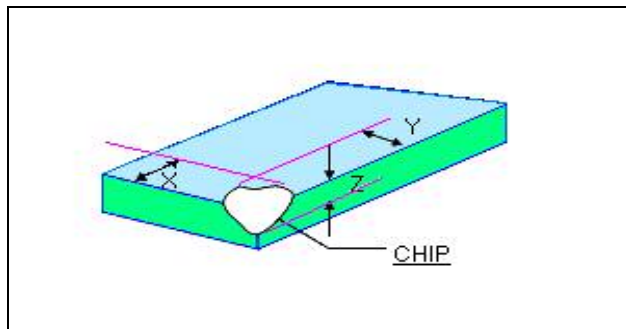

$X \leq 3\text{mm}$ ,  $Y \leq 3.0\text{mm}$  and  $Z \leq t \text{ mm}$ : It is acceptable  
(t: Glass Thickness)

## 7. Cautions

In order to prevent accidental use and to guarantee the performance of product, customers are requested to keep the following.

### 7-1 Storage

- 1) Store the products at the temperature and humidity range presented in the specification.
- 2) Store the products in the state of package.
- 3) Do not expose the product to a direct ray of the sun.

### 7-2 Unpacking

- 1) Do not hold tail to take out touch panels in the package.

### 7-3 Handling

- 1) Use gloves and finger coat to prevent stains on the touchscreen and injury by the sharp edge of the touchscreen.
- 2) Do not take hold of tail when handing the touchscreen.
- 3) Do not pile up touch panels.
- 4) Do not put anything on the touchscreen.
- 5) Do not fold the tail.
- 6) Clean off the touch panel with alcohol and soft clothes when necessary
- 7) Prevent alcohol from penetrating into the touchscreen.
- 8) Do not use organic solvents except for alcohol.

## **7-4 Assembling**

- 1) Avoid excessive force on the touchscreen.
- 2) Do not give unnecessary strain to the tail while assembling.

## **8. Warranty**

Touchscreen products manufactured to this specification shall be capable of meeting all characteristics for a minimum period of five years from the shipping date when stored or used as specified under normal conditions within the contents of these sheets.

If touchscreen products are not stored or used as specified herein, this five-year warranty can not be applicable